

EBS
Ink-Jet Systeme

HANDJET
EBS-250

HANDJET EBS-25

The HANDJET EBS 250 is an innovative product made by EBS Ink-Jet Systeme GmbH.

After continual intensive research and further development of the well known production line Ink-Jet printer PicAS EBS-200, we are now able to introduce the fully versatile, cable-free! HANDJET EBS-250. Marking the beginning of a new era in hand-coding.

The ultra-leight and compact design of the HANDJET EBS-250 (weighing, with batteries and ink cartridge less than 1000g) simplifies marking, coding and signing.

The HANDJET EBS-250 with its patented print technology replaces antiquated hand coders (such as stencil machines, stamps and roll coders, laborious and expensive in use and problematic with ink management).

Fast and clean printing on various surfaces such as; metal, glass, plastic and, of course, cardboard using many solvent based inks in different colours.

By efficient use of energy, the HANDJET EBS-250 can print up to 50 hours non-stop and the Li-Ion rechargeable battery needs less than 2,5 hours für recharging.

The easy to use Microsoft™ Windows®-based user interface programme transmits messages that have been created within seconds to the handcoder. Also pre-defined logos from Windows® fonts and symbols, as well as diacritical characters can be easily transferred. Included, are special registers like date, time, up- and down counters.

Up to 1500 characters can be efficiently stored in the handcoders memory with up to 10 message blocks with several lines in each block.



The ink cartridge lifetime is extremely long-lasting (up to 100 000 characters with dot matrix 7x5). Saving money on consumables.

The required messages are transferred by a RFI-radio frequency Interface (USB)



speedily to the HANDJET EBS-250 within a range of 50 metres. One PC can easily control several HANDJETs with one RFI.

HANDJET EBS-250: Ink-Jet technology for the future!



Technical Parameters

Number of nozzles	16
Nozzle diameter	150 µm
Print height	27 mm
Height of objects to be printed	from 35 mm
Working position in 3D space	any
Line printing	Enables printing of up to 10 texts in successive lines.
max. number of characters per text	1500 (including control characters for the printer's built-in fonts)
Number of texts and accompanying print-param.	from 1 to 10 (Texts are loaded into the printer via PC)
Printing of graphics (Logo, special Graphic characters)	Editing and printing of graphical texts and symbols with the use of Windows® (True Type) fonts as standard.
Special characters	National (diacritical) characters, graphic characters for information, warnings, etc.
Variable fields	Date and time in any format, expiry date, up- and down counters, universal counter (pieces, pallets, metres etc.)
Programming	<ul style="list-style-type: none"> Wireless (radio) with range of up to 50m), Text- and parameter processing Software, Windows® 98SE / ME / NT / 2000 / XP Network of up to 30 printers, radio-controlled via PC
Timing	Either synchronised with rotational speed of the lower stabilisor or at intervals by an internal generator

Power supply	Battery powered by 3 Li-Ion cells.
Approximate operating time with the battery fully charged	50 hours of non-stop printing at a temperature of 20°C, automatic low-battery indication.
Recharging	Automatically via an external 24V/1A DC power pack. Charging time - less than 150 minutes
Ink	Available in easily removable cartridges. Alcohol-, MEK- or water-based, in various colours.
Cartridge capacity	110 ml for printing about 100.000 characters with 7x5 dot matrix or about 17.000 characters with 16x10 dot matrix.
Working pressure	0,3 bar to 0,4 bar
Operating temp. range	+0,5°C to +40°C
Storage temperature range	<ul style="list-style-type: none"> +1°C to +45°C, with water-based ink -10°C to +45°C, with MEK or ethanol-based ink
Humidity	Up to 95% without steam condensation - the printer can be operated when it rains (on a dry surface).
Weight	980g +/- 10 g - printer with battery and full ink cartridge, without power pack and cable

EBS GmbH reserves the right to change these specifications without prior notice.

Accessories

Dimensions: side and front views

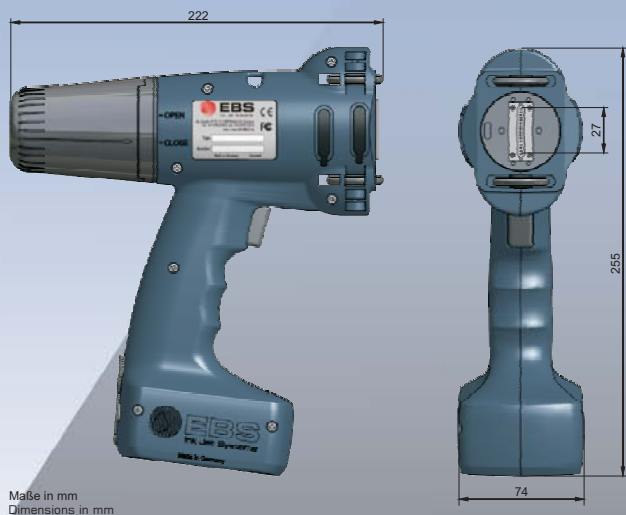

Maße in mm
Dimensions in mm

The printer in working position

Standard:

- Case to hold all accessories
- HANDJET EBS 250 Printer
- Ink Cartridge
- Power pack 24V/1A with cable
- CD with utility software and user-support files

optional

- RFI-Module for wireless data transfer (USB)
- Cable for RFI-Module to PC
- Stabilisor rolls for exact printing on curved surfaces



Patents: WO 99/48694
EP 1219439
EP 12194323

Protection of Designs



NCB MARKING EQUIPMENT LTD

PO BOX 662 - Brook Office - Evesbatch
Worcestershire - WR6 5BE

Tel: 01531 640400
Fax: 01531 640419
www.ncb-marking.co.uk
sales@ncb-marking.co.uk